

SUBARU

INSTALLATION
INSTRUCTIONS

DIFFERENTIAL PROTECTOR FOR LEGACY, FORESTER AND IMPREZA B0310SS000

Kit Contents

- 1 Differential Protector
- 2 Flange Head Bolts, M 10 - 1.25 X 60 mm (GR. 10.9) 14mm Head
- 2 Flange Head Bolts, M 10 - 1.25 X 45 mm (GR. 10.9) 14mm Head
- 2 Spacers, 32 mm Long
- 2 Spacers, 16 mm Long
- 4 Washers, M10

Tools Required

- 3/8" Ratchet
- 14mm Socket
- 17mm Socket
- Jacking Stand (to support exhaust)
- Torque Wrench
- Prying Wedge

READ ENTIRE INSTRUCTIONS PRIOR TO INSTALLATION

CAUTION: EXHAUST SYSTEM MAY BE HOT!

INSTALLATION INSTRUCTIONS

1. FOR FORESTER AND 2002 IMPREZA, SUPPORT EXHAUST WITH JACKING STAND, THEN REMOVE EXHAUST FROM 3 REAR HANGERS (2 AT MUFFLER, 1 AT REAR SUSPENSION). THIS IS NOT REQUIRED FOR LEGACY INSTALLATION.
2. LOCATE (4) FRONT MOUNT BOLTS ON DIFFERENTIAL (2 ON RIGHT AND 2 ON LEFT). REMOVE AND DISCARD.
3. LOOSEN REAR MOUNT NUTS UNTIL NUT IS FLUSH WITH END OF STUD.
CAUTION: DO NOT REMOVE.
4. PRY THE DIFFERENTIAL HOUSING FORWARD UNTIL SLOTS ON DIFFERENTIAL PROTECTOR WILL SLIDE BETWEEN REAR MOUNT AND DIFFERENTIAL HOUSING. SEE FIGURE 2.(NOT REQUIRED FOR 2002 IMPREZA)

NOTE: POSITION PRYING WEDGE AGAINST FLOOR PAN AND PUSH AGAINST REAR MOUNT STUD/NUT TO MOVE DIFFERENTIAL HOUSING FORWARD.

5. INSTALL FOUR (4) FRONT MOUNT BOLTS, WASHERS AND SPACERS (LONG BOLTS, WASHERS AND SPACERS - DRIVER SIDE/SHORT BOLTS, WASHERS AND SPACERS - PASSENGER SIDE). SEE FIGURE 1. HAND TIGHTEN ONLY DRIVER SIDE/SHORT BOLTS, WASHERS AND SPACERS - PASSENGER SIDE). SEE FIGURE 1. HAND TIGHTEN .
6. POSITION PROTECTOR AT REAR WITH SERVICE PLUGS CENTERED IN ACCESS HOLES, THEN TIGHTEN REAR MOUNT BOLTS TO 50.6 (±5.8) FT. LBS.
7. TIGHTEN FRONT MOUNT BOLTS TO 51.0 (±7.2) FT. LBS.
8. REINSTALL EXHAUST SYSTEM INTO HANGERS AND REMOVE JACKING STAND (IF APPLICABLE).

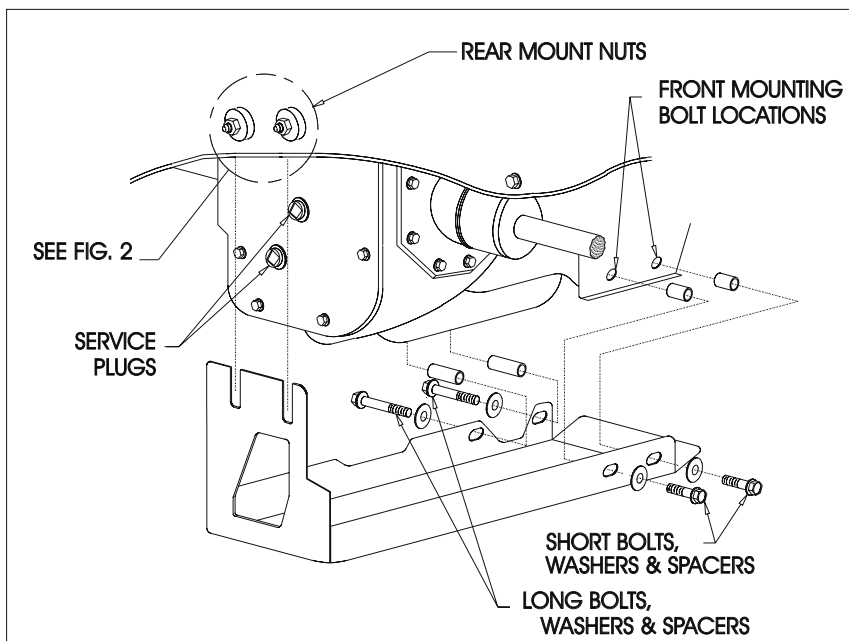

FIG. 1

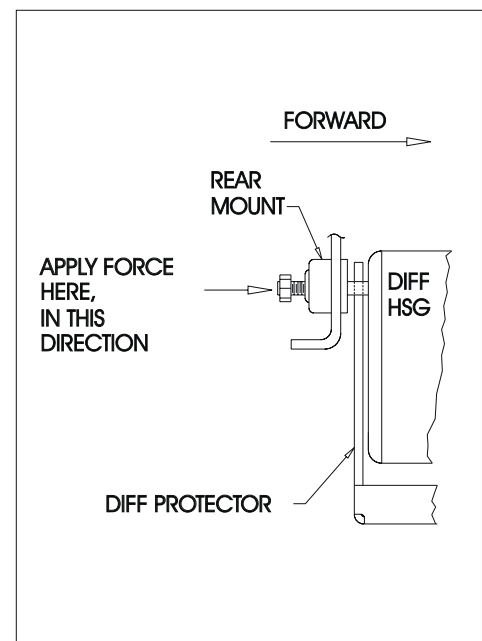

FIG. 2